



GRT 400

Model No. NTBE06900

Serial No. _____

Write the serial number in the space above for reference.

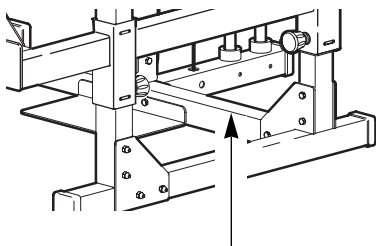

Serial Number Decal

QUESTIONS?

As a manufacturer, we are committed to providing complete customer satisfaction. If you have questions, or if there are missing parts, we will guarantee complete satisfaction through direct assistance from our factory.

TO AVOID UNNECESSARY DELAYS, PLEASE CALL DIRECT TO OUR TOLL-FREE CUSTOMER HOT LINE. The trained technicians on our customer hot line will provide immediate assistance, free of charge to you.

CUSTOMER HOT LINE:

1-888-825-2588

Mon.-Fri., 6 a.m.-6 p.m. MST

USER'S MANUAL

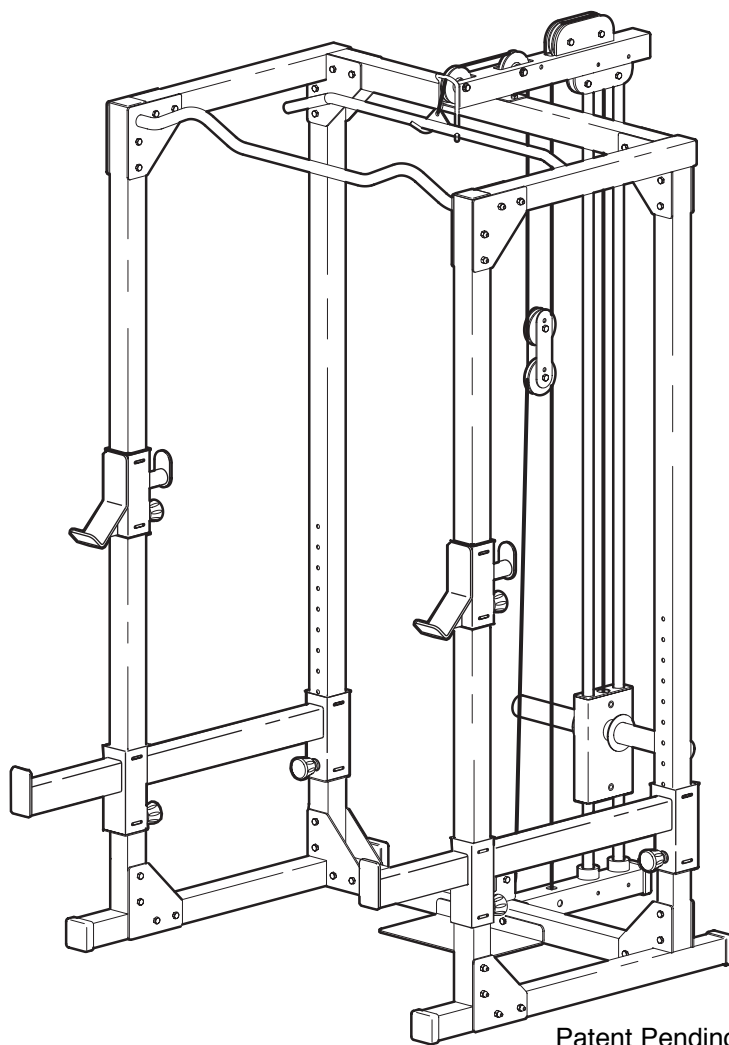

Patent Pending

CAUTION

Read all precautions and instructions in this manual before using this equipment. Save this manual for future reference.



Visit our website at

www.nordictrack.com

new products, prizes,
fitness tips, and much more!

Table of Contents

Warning Decal Placement	2
Important Precautions	3
Before You Begin	4
Part Identification Chart	5
Assembly	6
Adjusting the Weight Rack	11
Exercise Guidelines	13
Ordering Replacement Parts	Back Cover
Limited Warranty	Back Cover

Note: A Part List/Exploded Drawing is attached in the center of this manual. Remove the Part List/Exploded Drawing before beginning assembly.

Warning Decal Placement

The decal shown at right has been placed on the weight rack. If the decal is missing or illegible, call our Customer Service Department toll-free at 1-888-825-2588, Monday through Friday, 6 a.m. until 6 p.m. Mountain Time, to order a free replacement decal. Apply the replacement decal in the location shown.

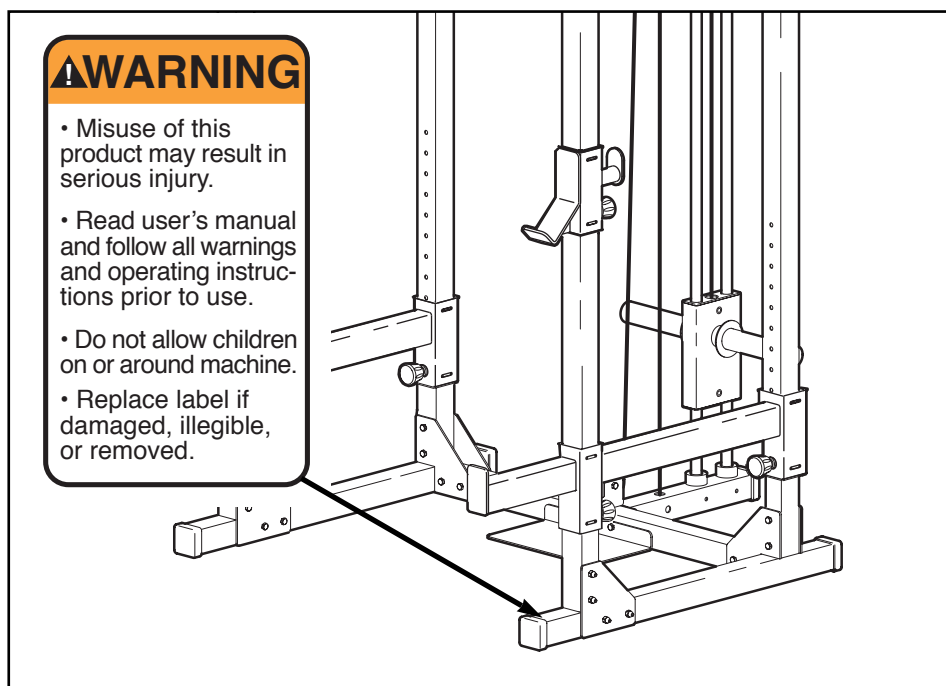

Important Precautions

⚠️ WARNING: To reduce the risk of serious injury, read the following important precautions before using the weight rack.

1. Read all instructions in this manual before using the weight rack. Use the weight rack only as described in this manual.
2. It is the responsibility of the owner to ensure that all users of the weight rack are adequately informed of all precautions.
3. The weight rack is intended for home use only. Do not use the weight rack in any commercial, rental, or institutional setting.
4. Use the weight rack only on a level surface. Cover the floor beneath the weight rack to protect the floor or carpet.
5. Inspect and tighten all parts each time you use the weight rack. Replace any worn parts immediately.
6. Keep children under 12 and pets away from the weight rack at all times.
7. Keep hands and feet away from moving parts.
8. Always wear athletic shoes for foot protection while exercising.
9. Always set both weight rests and both weight spotters at the same height.
10. Always make sure there is an equal amount of weight on each end of the barbell (not included).
11. Do not place more than 300 pounds, including the barbell, on the weight rests. Do not place more than 150 pounds on the weight carriage.
12. Make sure that the cables remain on the pulleys at all times. If the cables bind as you are exercising, stop immediately and make sure that the cables are on the pulleys.
13. Always secure the weights (not included) with the weight clips when they are mounted on the weight carriage.
14. Always exercise with a partner. When you are performing squat exercises, your partner should stand behind you to catch the barbell if you cannot complete a repetition.
15. If you feel pain or dizziness at any time while exercising, stop immediately and begin cooling down.
16. Always disconnect the lat bar from the weight rack when performing an exercise that does not require the lat bar.

⚠️ WARNING: Before beginning this or any exercise program, consult your physician. This is especially important for persons over the age of 35 or persons with pre-existing health problems. Read all instructions before using. ICON assumes no responsibility for personal injury or property damage sustained by or through the use of this product.

Before You Begin

Thank you for selecting the versatile NordicTrack® GRT 400 weight rack. The NordicTrack® GRT 400 is designed to help you develop every major muscle group of the body. Whether your goal is a shapely figure, dramatic increase in muscle size and strength, or a healthier cardiovascular system, the GRT 400 will help you achieve the specific results you want.

For your benefit, read this manual carefully before using the weight rack. If you have additional questions, please call our Customer Service Department

toll-free at 1-888-825-2588, Monday through Friday, 6 a.m. until 6 p.m. Mountain Time (excluding holidays). To help us assist you, please note the product model number and serial number before calling. The model number is NTBE06900. The serial number can be found on a decal attached to the weight rack (see the front cover of this manual).

Before reading further, please review the drawing below and familiarize yourself with the parts that are labeled.

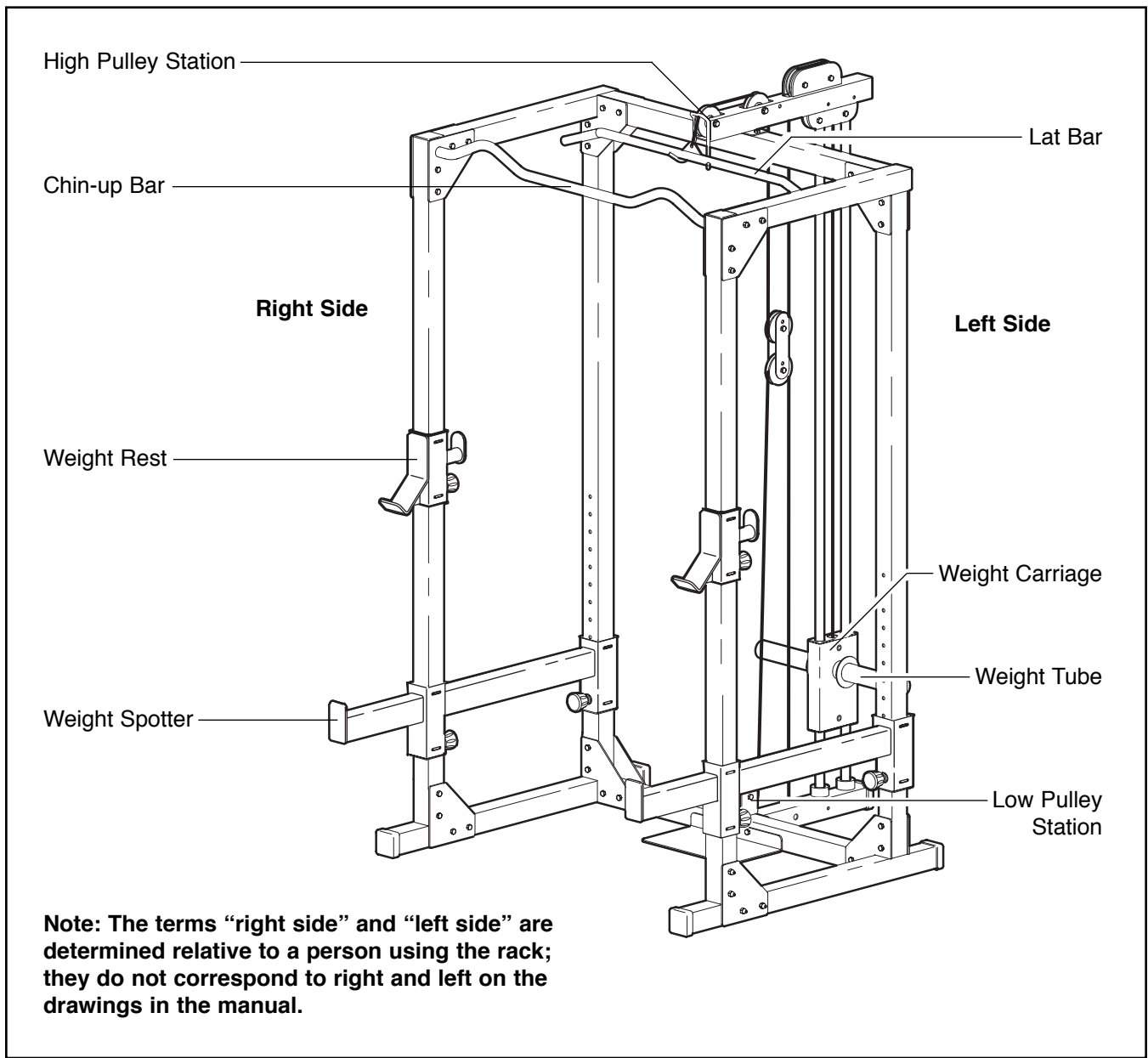

Part Identification Chart—Model No. NTBE06900

R1100A

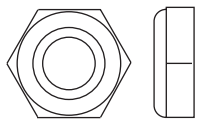

3/8" Nylon Jam Nut (48)

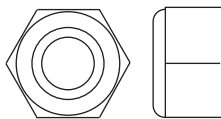

3/8" Nylon Locknut (29)

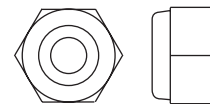

5/16" Nylon Locknut (30)



2" Spacer (39)



15/16" Spacer (40)



3/4" Spacer (38)

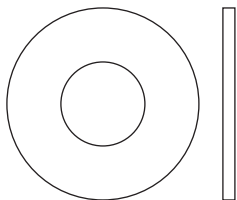

3/8" Washer (37)

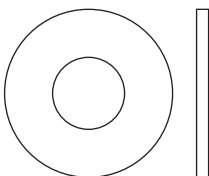

5/16" Washer (36)



5/16" x 2" Bolt (33)

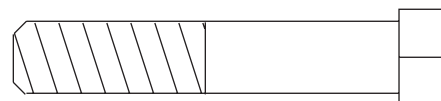

3/8" x 2" Bolt (32)

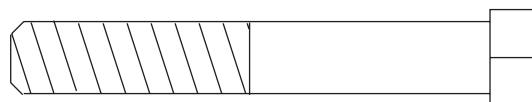

3/8" x 2 1/2" Bolt (35)

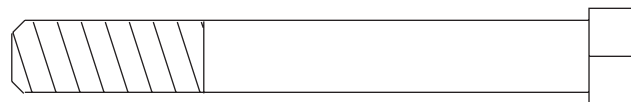

3/8" x 3" Bolt (34)

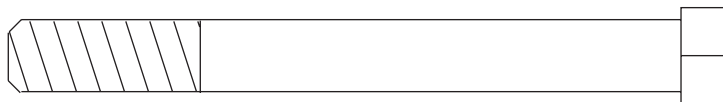

3/8" x 3 1/2" Bolt (31)



5/16" x 4" Bolt (49)

Assembly

Make Things Easier for Yourself!



Everything in this manual is designed to ensure that the weight rack can be assembled successfully by anyone. However, it is important to realize that the versatile weight rack has many parts and that the assembly process will take time. Most people find that by setting aside plenty of time, assembly will go smoothly.

Before beginning assembly, carefully read the following information and instructions:

- Assembly requires two people.
- Place all parts in a cleared area and remove the packing materials. Do not dispose of the packing materials until assembly is completed.
- Tighten all parts as you assemble them, unless instructed to do otherwise.

- As you assemble the weight rack, make sure all parts are oriented as shown in the drawings.
- For help identifying small parts, use the PART IDENTIFICATION CHART on page 5.

The following tools (not included) are required for assembly:

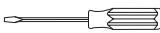
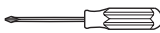
- **Two adjustable wrenches** 
- **One rubber mallet** 
- **One standard screwdriver** 
- **One Phillips screwdriver** 
- **Lubricant, such as grease or petroleum jelly, and soapy water.**

Assembly will be more convenient if you have a socket set, a set of open-end or closed-end wrenches, or a set of ratchet wrenches.

1. Press four 2 1/2" Square Outer Caps (27) onto the ends of the Right and Left Bases (1, 3).

Attach the Right and Left Bases (1, 3) to the Center Base (2) using four 3/8" x 3 1/2" Bolts (31) and four 3/8" Nylon Locknuts (29). **Do not tighten the Nylon Locknuts yet.**

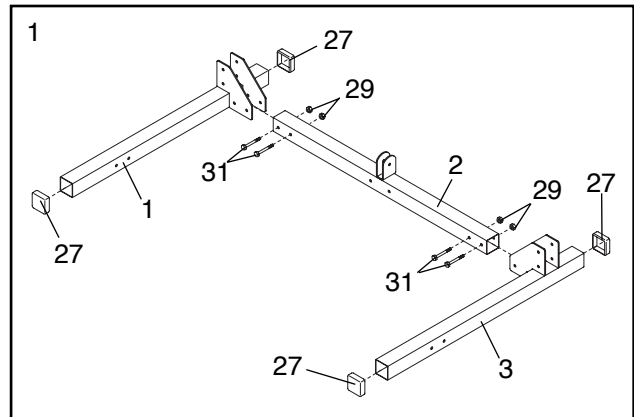

2. Identify the two Rear Uprights (8), which are slightly shorter than the Front Uprights (not shown).

Attach the Rear Uprights (8) to the Left and Right Bases (1, 3) using four 3/8" x 3 1/2" Bolts (31) and four 3/8" Nylon Locknuts (29). **Do not tighten the Nylon Locknuts yet. Make sure the Uprights are oriented exactly as shown, with the adjustment holes on the indicated side near the bottom.**

Press a 2 1/2" Square Outer Cap (27) onto the end of the Weight Guide Base (4).

Orient the Foot Plate (5) and the Weight Guide Base (4) as shown. Attach the Foot Plate and the Weight Guide Base to the Center Base (2) using two 3/8" x 3 1/2" Bolts (31) and two 3/8" Nylon Locknuts (29). **Do not tighten the Nylon Locknuts yet.**

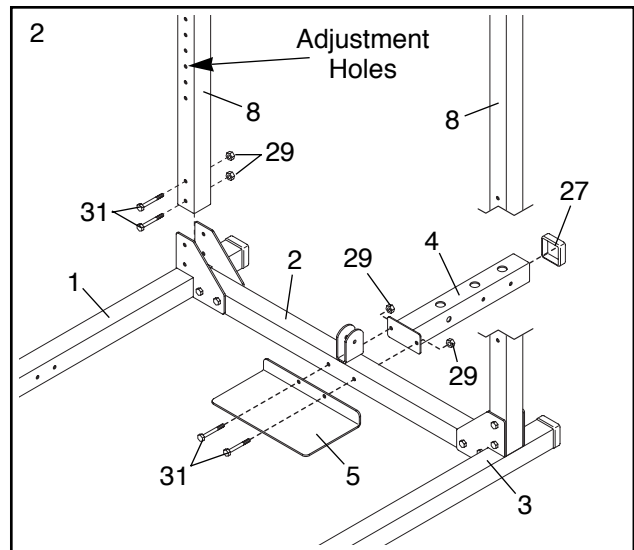

3. Tap a 2 1/2" Square Inner Cap (28) into each of the Front Uprights (7).

Attach one of the Front Uprights (7) and two Joint Plates (6) to the Left Base (3) using four 3/8" x 3 1/2" Bolts (31) and four 3/8" Nylon Locknuts (29). **Make sure the Front Upright is oriented so that the holes on the bottom of the Front Upright and the holes in the Joint Plates line up. If they do not line up, turn the Front Upright upside-down. Do not tighten the Nylon Locknuts yet. Make sure the Front Upright is turned so the adjustment holes are facing the Rear Upright (8).**

Attach the other Front Upright (7, not shown) and two Joint Plates (6, not shown) to the Right Base (1) in the same manner.

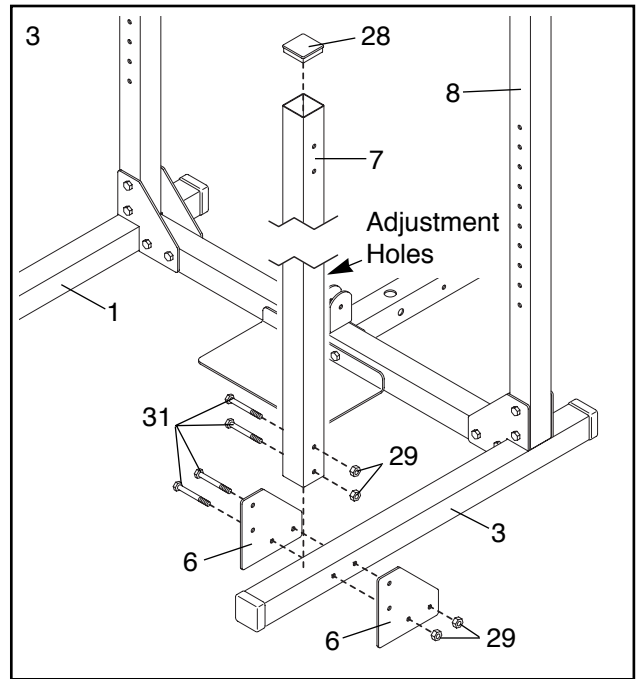

4. **This step will require two people.**

Refer to drawing 4a. Have one person hold out the Adjustment Knobs (22) on a Safety Spotter (20), while the other person slides the Safety Spotter down over the right Uprights (7, 8), as shown. Hold the Adjustment Knob out on the Weight Rest (19), and slide the Weight Rest onto the Front Upright (7). **To avoid breaking the Square Bushings (21) inside the top and bottom of the Safety Spotter and Weight Rest, be careful not to catch the Square Bushings on the edges of the Uprights as they slide on.**

Refer to drawing 4b. Secure the Safety Spotter (20) and the Weight Rest (19) to the right Uprights (7, 8) by snapping the three Adjustment Knobs (22) into adjustment holes in the Uprights and turning them clockwise until tight.

Assemble the other Safety Spotter (20) and Weight Rest (19) to the left Uprights (7, 8) in the same manner. **Make sure both Safety Spotters and both Weight Rests are at the same height.**

5. Attach the Chin-up Bar (13) and two Joint Plates (6) to the Front Uprights (7) using four 3/8" x 3 1/2" Bolts (31) and four 3/8" Nylon Locknuts (29). **Do not tighten the Nylon Locknuts yet.**

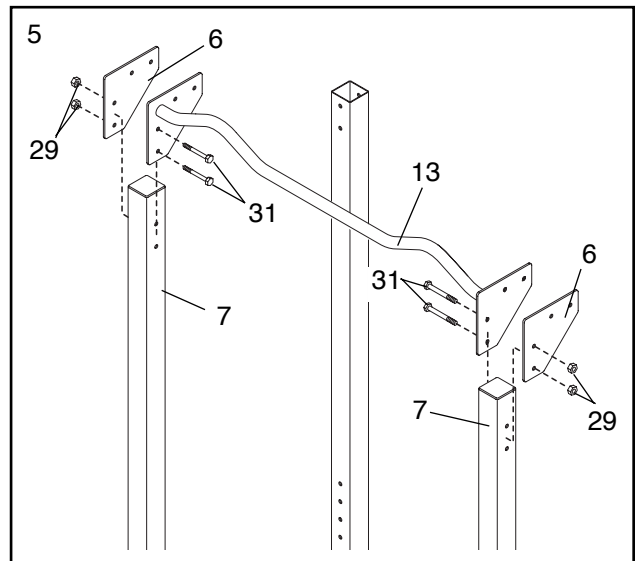
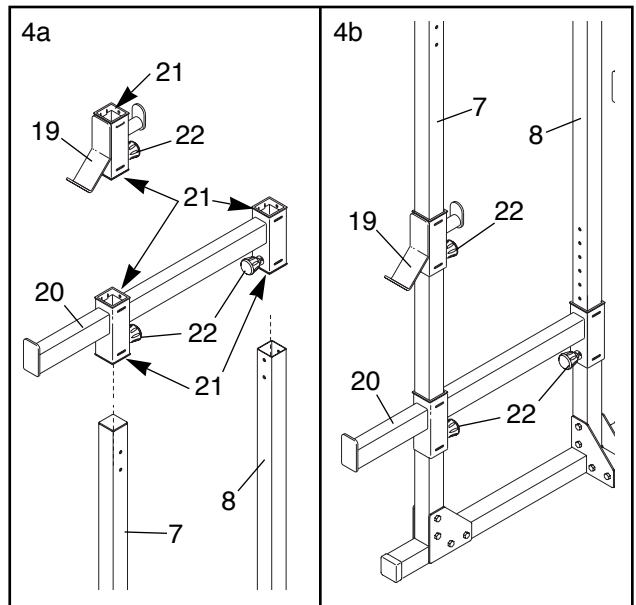

- Press a 2 1/2" Square Inner Cap (28) into the Left Frame (12). Attach the Left Frame to the left Uprights (7, 8) using four 3/8" x 3 1/2" Bolts (31) and four 3/8" Nylon Locknuts (29). **Do not tighten the Nylon Locknuts yet.**

Assemble the Right Frame (10) to the right Uprights (7, 8) in the same manner.

Attach the Center Frame (11) to the Left Frame (12) and the Right Frame (10) using four 3/8" x 3 1/2" Bolts (31) and four 3/8" Nylon Locknuts (29).

Tighten all Nylon Locknuts used in steps 1–6.

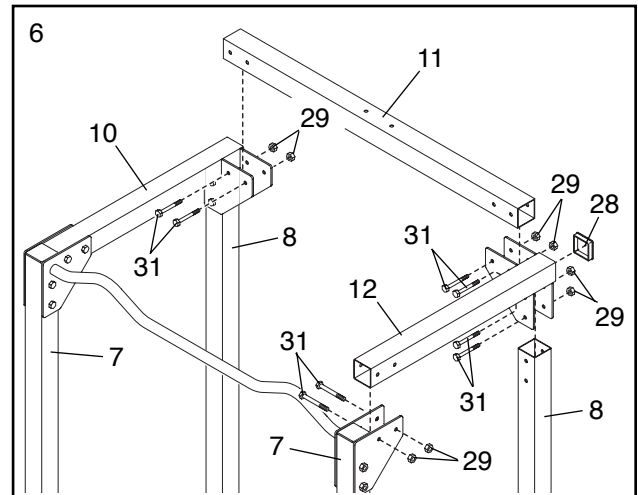

- Press the two 2" Round Inner Caps (42) into the weight tubes on the Weight Carriage (15).

Make sure the Weight Carriage is turned so the weight tubes are near the top, as shown. Attach the lower Carriage Bushing using a 3/8" x 2 1/2" Bolt (35), two 3/8" Washers (37), the 2" Spacer (39), and a 3/8" Nylon Jamnut (48).

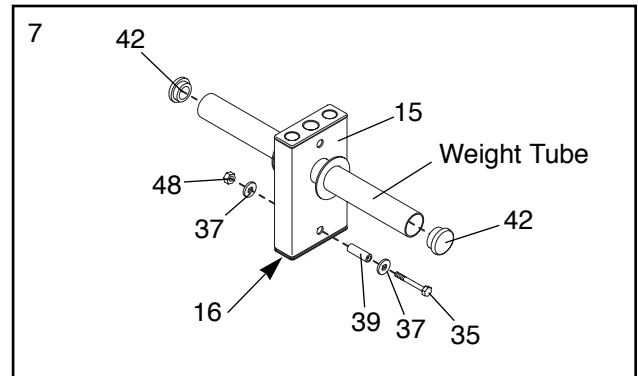

- Set the two Weight Bumpers (18) over the indicated holes in the Weight Guide Base (4). Hold the Weight Carriage (15) on top of the Weight Bumpers.

Insert the two Weight Guides (9) into the Weight Carriage (15), the Weight Bumpers (18), and the Weight Guide Base (4). Attach the Weight Guides using two 5/16" x 4" Bolts (49), four 5/16" Washers (36), and two 5/16" Nylon Locknuts (30).

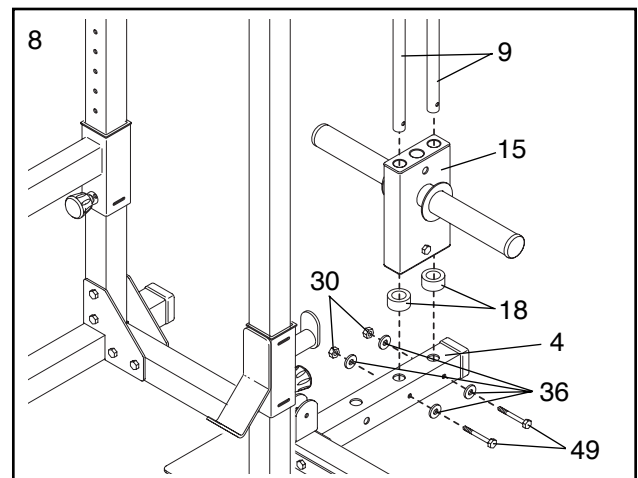

- Press a 2 1/2" Square Inner Cap (28) into the end of the Weight Guide Frame (14). Wipe the lat bar rests on the Weight Guide Frame with lubricant. Slide the Lat Bar Rest Covers (47) onto the lat bar rests.

Hold the Weight Guide Frame (14) on top of the Center Frame (11) and the Weight Guides (9). Attach the Weight Guides to the Weight Guide Frame using two 5/16" x 2" Bolts (33), four 5/16" Washers (36), and two 5/16" Nylon Locknuts (30).

Attach the Weight Guide Frame (14) to the Center Frame (11) using two 3/8" x 3 1/2" Bolts (31), two 3/8" Washers (37), and two 3/8" Nylon Locknuts (29).

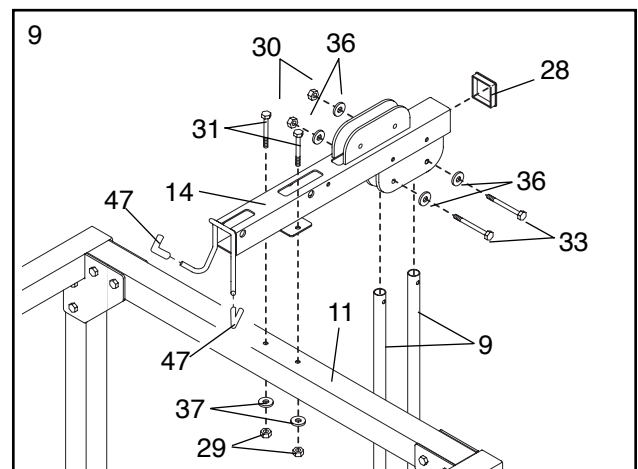

10. Locate a Cable (25) and notice that there is a ball on one end of the Cable and a metal sleeve on the other end.

Route the metal-sleeve end of the Cable (25) up under the lat bar rest on the Weight Guide Frame (14), down through the indicated hole, back up through the next hole, and then down through the hole between the Weight Guides (9) as shown.

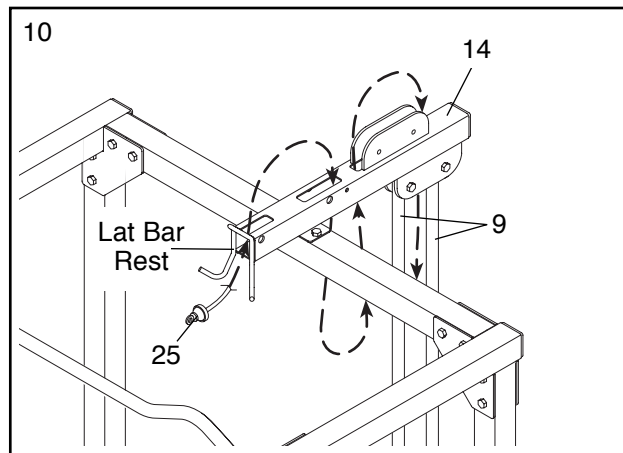

11. Insert the end of the Cable (25) into the hole in the center of the Weight Carriage (15). Attach the Cable using a 3/8" x 2 1/2" Bolt (35), two 3/8" Washers (37), two 3/4" Spacers (38), and a 3/8" Nylon Jamnut (48).

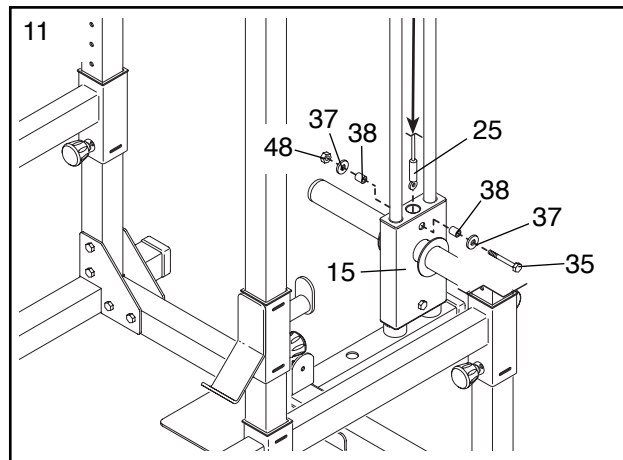

12. Lift the Cable (25) in the location shown. Attach two 3 1/2" Pulleys (24) inside the bracket on the Weight Guide Frame (14) using two 3/8" x 2" Bolts (32) and two 3/8" Nylon Locknuts (29).

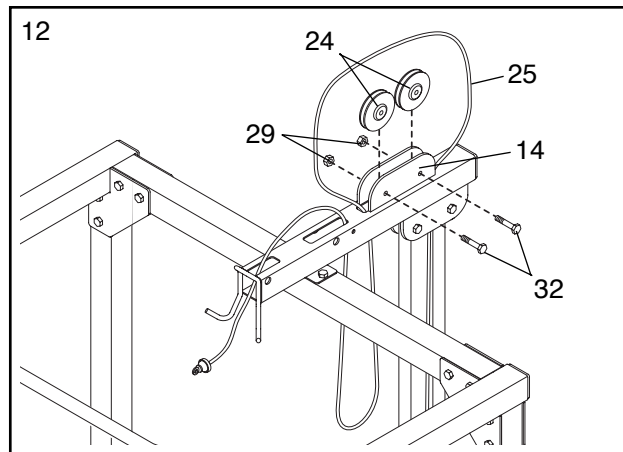

13. Lift the Cable (25) in the location shown. Attach two 3 1/2" Pulleys (24) inside the Weight Guide Frame (14) using two 3/8" x 3" Bolts (34), four 3/8" Washers (37), four 3/4" Spacers (38), and two 3/8" Nylon Locknuts (29).

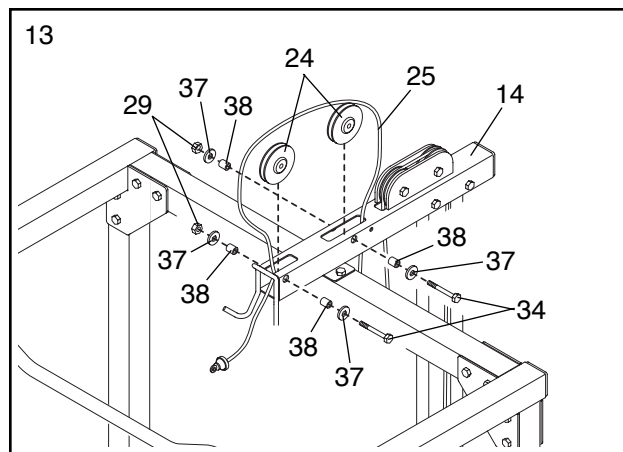

- Pull the Cable (25) down in the indicated location, so there is no slack at the ends of the Cable.

Locate the other Cable (25). Insert the metal-sleeve end of the Cable into the indicated hole in the Weight Guide Base (4). Attach the Cable using a 3/8" x 3" Bolt (34), two 3/8" Washers (37), two 15/16" Spacers (40), and a 3/8" Nylon Locknut (29).

Route the ball-end of the Cable (25) through the bracket on the Center Base (2). Attach a 4" Pulley (50) inside the bracket using a 3/8" x 2" Bolt (32) and a 3/8" Nylon Locknut (29).

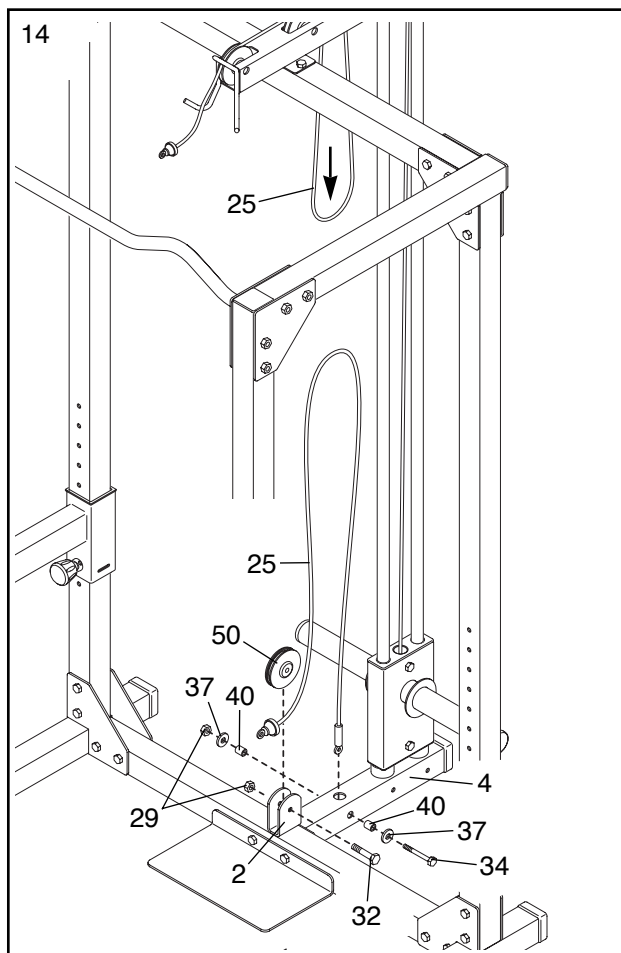

- Wrap the upper Cable (25) around a 3 1/2" Pulley (24) as shown. Attach the 3 1/2" Pulley and a Cable Trap (23) to the two Pulley Plates (17) using a 3/8" x 2" Bolt (32) and a 3/8" Nylon Locknut (29).

Wrap the other Cable (25) around a 3 1/2" Pulley (24) as shown. Attach the 3 1/2" Pulley and a Cable Trap (23) to the Pulley Plates (17) using a 3/8" x 2" Bolt (32) and a 3/8" Nylon Locknut (29).

Make sure the Bolts (32) are inserted through the highest and lowest holes in the Pulley Plates (17), and that the Cables (25, 26) are between the Cable Traps (23) and the 3 1/2" Pulleys (24).

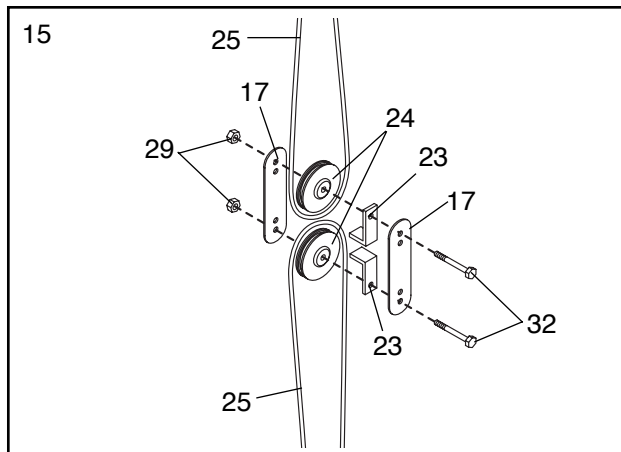

- Wet the ends of the Lat Bar (45) with a small amount of soapy water. Slide the Handgrips (41) onto the ends of the Lat Bar.

- Make sure all parts of the weight rack are properly tightened. In addition, pull each cable a few times to make sure the cables move smoothly over the pulleys. If the cables do not move smoothly, locate and correct the problem. When weights are used, the cables may be damaged if they are incorrectly routed.**

The use of all remaining parts will be explained in ADJUSTING THE WEIGHT RACK, beginning on page 11.

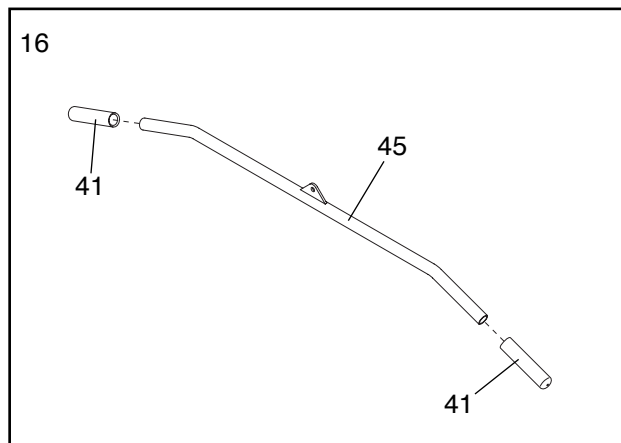

Adjusting the Weight Rack

This section explains how to adjust the weight rack. See the Exercise Guidelines on page 13 for important information about how to get the most benefit from your exercise program. Also, refer to the accompanying exercise poster to see the correct form for each exercise.

Inspect and tighten all parts each time you use the weight rack. Replace any worn parts immediately. The weight rack can be cleaned with a damp cloth and a mild, non-abrasive detergent. Do not use solvents.

USING THE WEIGHT RESTS AND WEIGHT SPOTTERS

Before beginning an exercise, move the Weight Rests (19) and the Weight Spotters (20) to sets of holes in the Uprights (7,8) that are best suited for that exercise. Do this by turning the Adjustment Knobs (22) counterclockwise until loose. Pull the Knobs out and slide the Weight Rests or the Weight Spotters to the desired height. Snap the Knobs into the adjustment holes on the Uprights and turn the Knob clockwise until tight.

The selected holes for the Weight Spotters (20) should represent the lowest point to which you want the barbell to go during the exercise. The selected holes for the Weight Rests (19) should be at a comfortable height for lifting and replacing the barbell. Perform the exercise as shown in the accompanying Exercise Poster. **Note:** Make sure the Adjustment Knobs (22) are fully tightened.

⚠ WARNING: Always set both Weight Rests (19) at the same height and both Weight Spotters (20) at the same height.

SETTING UP FOR SQUAT EXERCISES

Squat exercises should be performed inside the rack (behind the dotted line in the picture). When performing squat exercises, set the Weight Rests (19) and the Weight Spotters (20) at a comfortable height in the manner described in USING THE WEIGHT RESTS AND WEIGHT SPOTTERS, above.

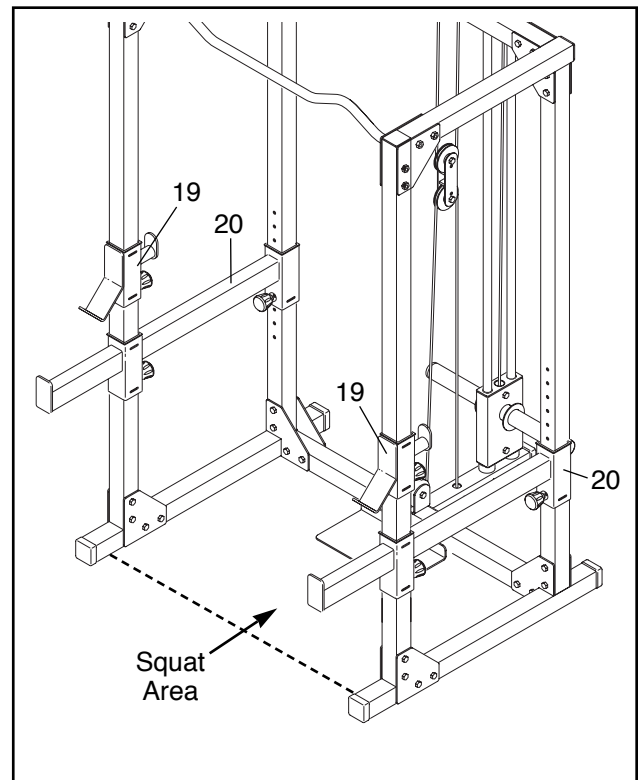
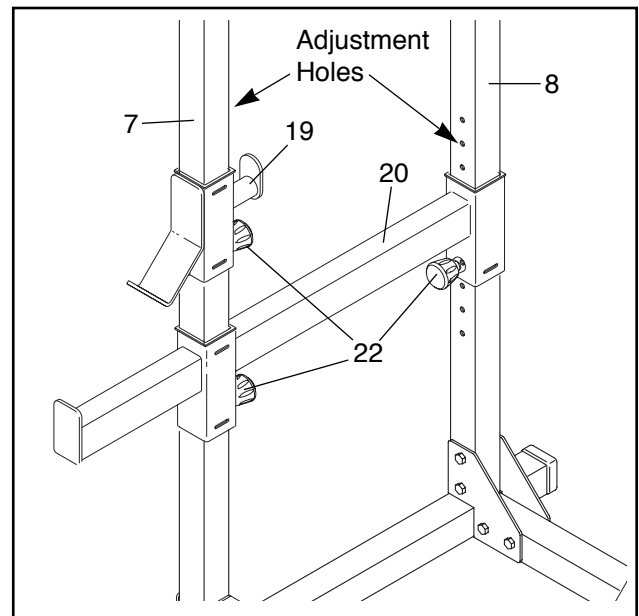

ATTACHING WEIGHTS TO THE WEIGHT CARRIAGE

To use the high or low pulley station, slide the desired amount of weight onto the weight tubes of the Weight Carriage (15) and secure the weights with Weight Clips (43).

⚠ WARNING: Do not place more than 150 pounds on the Weight Carriage (15). Always place the same amount of weight on each side of the Weight Carriage, and secure the weights on the Weight Carriage with the Weight Clips (43).

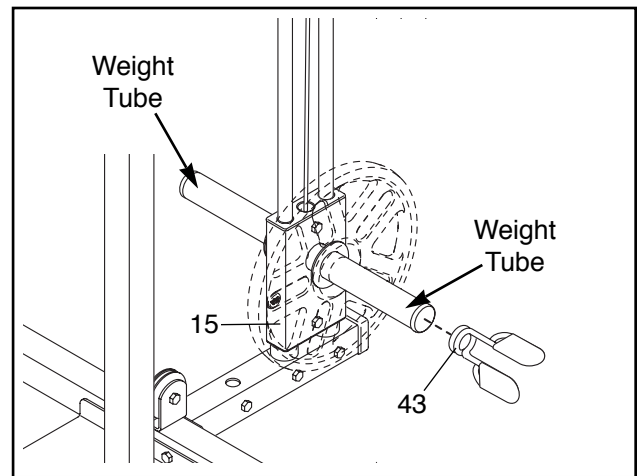

ATTACHING THE LAT BAR TO THE HIGH PULLEY STATION OR THE LOW PULLEY STATION

To use the high pulley station or the low pulley station, first place the desired weights on the weight carriage (see ATTACHING WEIGHTS TO THE WEIGHT CARRIAGE above). Next, attach the Lat Bar (45) to either Cable (25) with a Cable Clip (46).

⚠ WARNING: Always disconnect the Lat Bar (45) when performing an exercise that does not require using the Lat Bar.

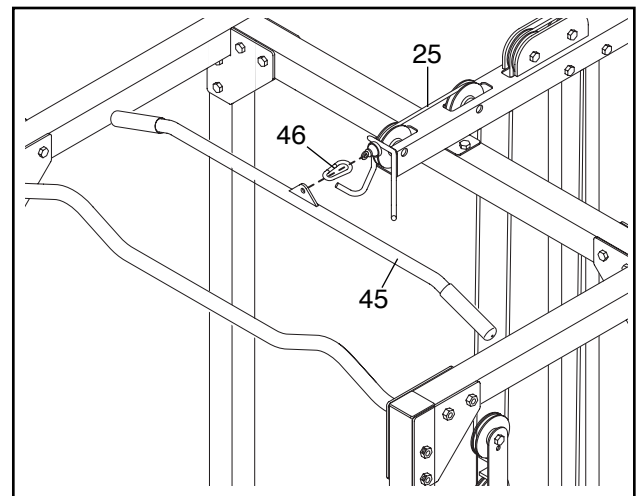

TIGHTENING THE CABLES

Woven cable, the type of cable used on the weight rack, can stretch slightly after it is first used. If there is slack in the cables, tighten them as described below.

Remove the 3/8" x 2" Bolt (32) and the 3/8" Nylon Locknut (29) attaching the lower 3 1/2" Pulley (24) and Cable Trap (23) to the two Pulley Plates (17). Reattach the lower 3 1/2" Pulley and Cable Trap to the higher holes in the Pulley Plates using the Bolt and Nylon Locknut.

If moving the lower 3 1/2" Pulley (24) does not sufficiently tighten the cables, you can also move the upper 3 1/2" Pulley down one set of holes in the Pulley Plates (17).

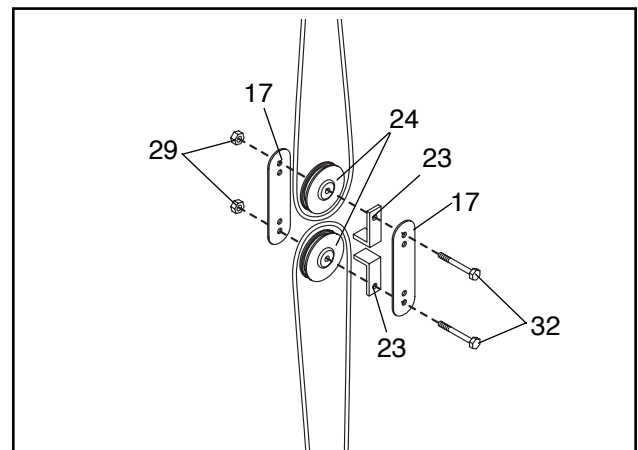

Exercise Guidelines

THE FOUR BASIC TYPES OF WORKOUTS

Muscle Building

The only way to increase the size and strength of your muscles is to push them close to their maximum capacity. When you progressively increase the intensity of your exercise, your muscles will continually adapt and grow. You can tailor the individual exercise to the proper intensity level in two ways:

- by changing the amount of weight used
- by changing the number of repetitions or sets performed (A “repetition” is one complete cycle of an exercise, such as one sit-up. A “set” is a series of repetitions).

The proper amount of weight for each exercise obviously depends upon the individual user. You must gauge your limits and select the amount of weight that is right for you. Begin with 3 sets of 8 repetitions for each exercise you perform. Rest for 3 minutes after each set. When you can complete 3 sets of 12 repetitions without difficulty, increase the amount of weight.

Toning

You can tone your muscles by pushing them to a moderate percentage of their capacity. Select a moderate amount of weight and increase the number of repetitions in each set. Complete as many sets of 15 to 20 repetitions as possible without discomfort. Rest for 1 minute after each set. Work your muscles by completing more sets rather than by using high amounts of weight.

Weight Loss

To lose weight, use a low amount of weight and increase the number of repetitions in each set. Exercise for 20 to 30 minutes, resting for a maximum of 30 seconds between sets.

Cross Training

Many people desire a complete and balanced fitness program. Cross training is an efficient way to accomplish this. One example of a balanced program is:

- Plan weight training workouts on Monday, Wednesday, and Friday.
- Plan 20 to 30 minutes of aerobic exercise, such as cycling, running, or swimming on Tuesday and Thursday.
- Rest from both weight training and aerobic exercise for at least one full day each week to give your body time to regenerate.

The combination of weight training and aerobic exercise will reshape and strengthen your body and develop your heart and lungs.

PERSONALIZING YOUR EXERCISE PROGRAM

Specifying the exact length of time for each workout, as well as the number of repetitions or sets for each exercise, is a highly individual matter. It is very important to avoid overdoing it during the first few months of your exercise program. You should progress at your own pace and be sensitive to your body's signals. If you experience pain or dizziness at any time while exercising, stop immediately and begin cooling down. Find out what is wrong before continuing. Remember that adequate rest and a proper diet are important factors in any exercise program.

WARMING UP

Begin each workout with 5 to 10 minutes of stretching and light exercise to warm up. Warming up prepares your body for more strenuous exercise by increasing circulation, raising your body temperature and delivering more oxygen to your muscles.

WORKING OUT

Each workout should include 6 to 10 different exercises. Select exercises for every major muscle group with emphasis on the areas that you want to develop the most. To give balance and variety to your workouts, vary the exercises from session to session.

Schedule your workouts for the time of day when your energy level is the highest. Each workout should be followed by at least one day of rest. Once you find the schedule that is right for you, stick with it.

EXERCISE FORM

You will gain the greatest benefits from exercising by maintaining proper form. This requires moving through the full range of motion for each exercise and moving only the appropriate parts of the body. Exercising in an uncontrolled manner will leave you feeling exhausted. On the exercise poster accompanying this manual, you will find photographs showing the correct form for several exercises. A description of each exercise is also provided, along with a list of the muscles affected. Refer to the muscle chart on page 14 to find the locations of the muscles.

The repetitions in each set should be performed smoothly and without pausing. The exertion stage of each repetition should last about half as long as the return stage. Proper breathing is important. Exhale during the exertion stage of each repetition and inhale during the return stroke. Never hold your breath!

Make sure to rest for a short period of time after each set. The ideal resting periods are:

- Rest for three minutes after each set for a muscle building workout.
- Rest for one minute after each set for a toning workout.
- Rest for 30 seconds after each set for a weight loss workout.

Plan to spend the first couple of weeks familiarizing yourself with the equipment and learning the proper form for each exercise.

COOLING DOWN

End each workout with 5 to 10 minutes of stretching. Include stretches for both your arms and legs. Move slowly as you stretch and do not bounce. Ease into

each stretch gradually and go only as far as you can without strain. Stretching at the end of each workout is very effective for increasing flexibility.

STAYING MOTIVATED

For motivation, keep a record of each workout. The chart on page 15 of this manual can be photocopied and used to schedule and record your workouts. List the date, the exercises performed, the weight plus the numbers of sets and repetitions completed. Record your weight and key body measurements at the end of every month.

Remember, the key to achieving the greatest results is to make exercise a regular and enjoyable part of your everyday life.

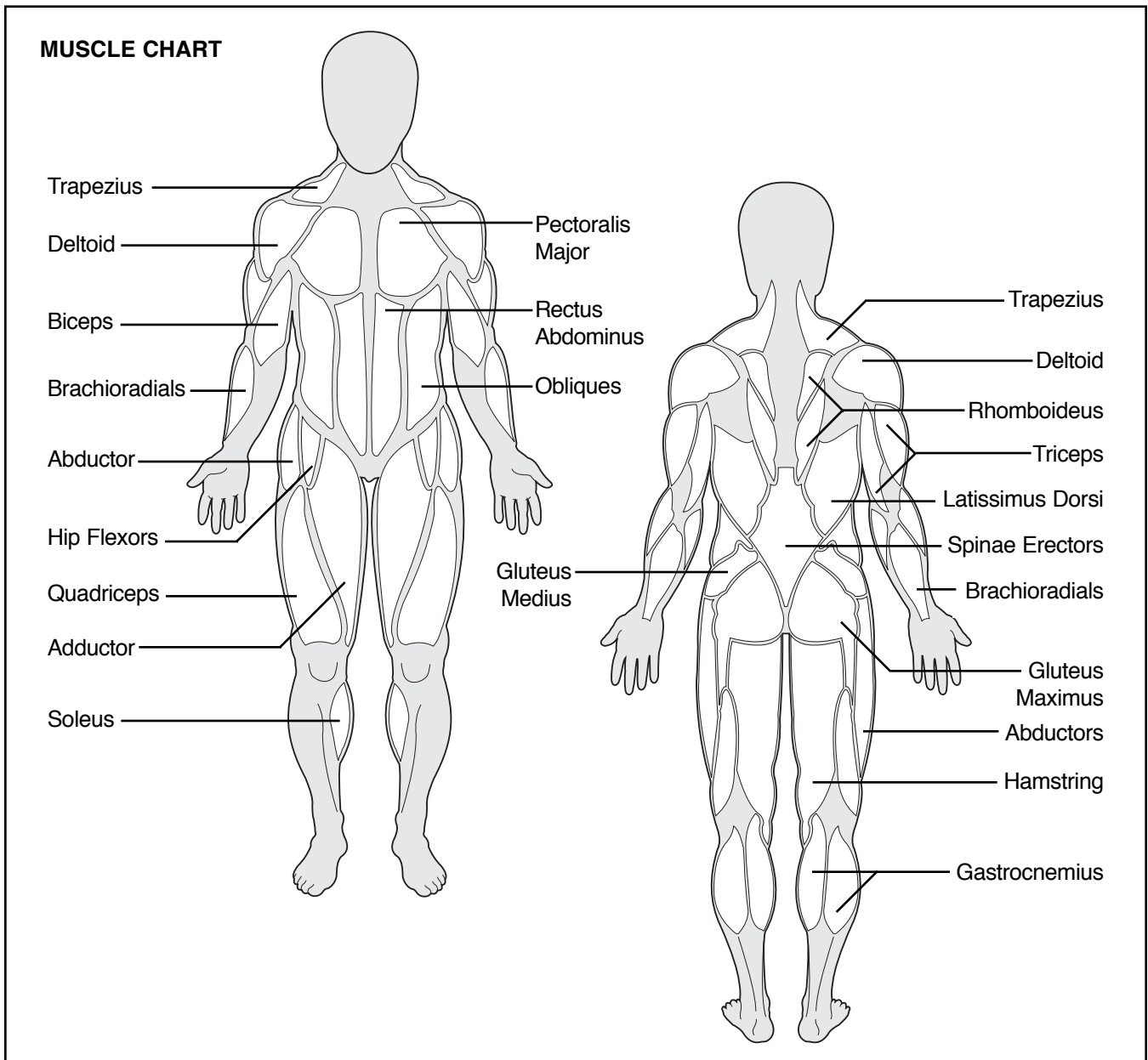

MONDAY Date: _____ / /	EXERCISE	WEIGHT	SETS	REPS

TUESDAY **AEROBIC EXERCISE**
 Date: _____
 / /

WEDNESDAY Date: _____ / /	EXERCISE	WEIGHT	SETS	REPS

THURSDAY **AEROBIC EXERCISE**
 Date: _____
 / /

FRIDAY Date: _____ / /	EXERCISE	WEIGHT	SETS	REPS

Make photocopies of this page for scheduling and recording your workouts.

Ordering Replacement Parts

To order replacement parts, simply call our Customer Service Department toll-free at 1-888-825-2588, Monday through Friday, 6 a.m. until 6 p.m. Mountain Time (excluding holidays). To help us assist you, please be prepared to give the following information when calling:

- The MODEL NUMBER of the product (NTBE06900)
- The NAME of the product (NordicTrack® GRT 400 weight rack)
- The SERIAL NUMBER of the product (see the front cover of this manual)
- The KEY NUMBER and DESCRIPTION of the desired part(s) (see the PART LIST and the EXPLODED DRAWING at the center of this manual).

Limited Warranty

ICON Health & Fitness, Inc. (ICON), warrants this product to be free from defects in workmanship and material, under normal use and service conditions, for a period of ninety (90) days from the date of purchase. This warranty extends only to the original purchaser. ICON's obligation under this warranty is limited to replacing or repairing, at ICON's option, the product at one of its authorized service centers. All products for which warranty claim is made must be received by ICON at one of its authorized service centers with all freight and other transportation charges prepaid, accompanied by sufficient proof of purchase. All returns must be pre-authorized by ICON. This warranty does not extend to any product or damage to a product caused by or attributable to freight damage, abuse, misuse, improper or abnormal usage or repairs not provided by an ICON authorized service center, products used for commercial or rental purposes, or products used as store display models. No other warranty beyond that specifically set forth above is authorized by ICON.

ICON is not responsible or liable for indirect, special or consequential damages arising out of or in connection with the use or performance of the product or damages with respect to any economic loss, loss of property, loss of revenues or profits, loss of enjoyment or use, costs of removal, installation or other consequential damages of whatsoever nature. Some states do not allow the exclusion or limitation of incidental or consequential damages. Accordingly, the above limitation may not apply to you.

The warranty extended hereunder is in lieu of any and all other warranties and any implied warranties of merchantability or fitness for a particular purpose is limited in its scope and duration to the terms set forth herein. Some states do not allow limitations on how long an implied warranty lasts. Accordingly, the above limitation may not apply to you.

This warranty gives you specific legal rights. You may also have other rights which vary from state to state.

ICON HEALTH & FITNESS, INC., 1500 S. 1000 W., LOGAN, UT 84321-9813

REMOVE THIS PART LIST/EXPLODED DRAWING FROM THE MANUAL

SAVE THIS PART LIST/EXPLODED DRAWING FOR FUTURE REFERENCE

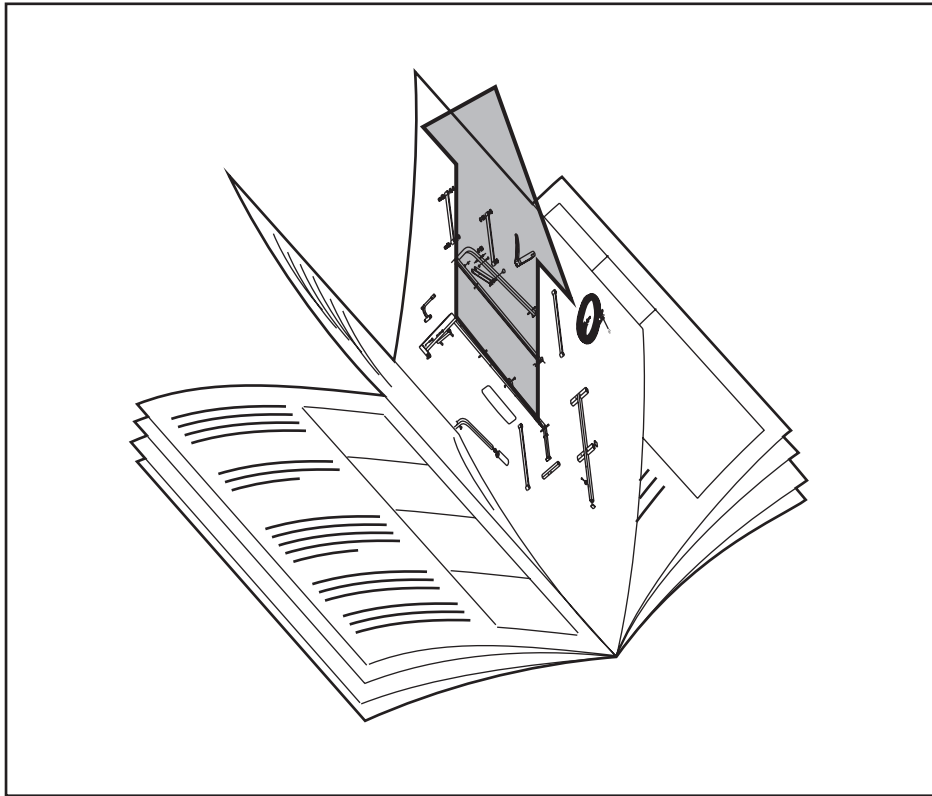

Part List—Model No. NTBE06900

R1100A

Key No.	Qty.	Description	Key No.	Qty.	Description
1	1	Right Base	27	5	2 1/2" Square Outer Cap
2	1	Center Base	28	5	2 1/2" Square Inner Cap
3	1	Left Base	29	44	3/8" Nylon Locknut
4	1	Weight Guide Base	30	4	5/16" Nylon Locknut
5	1	Foot Plate	31	36	3/8" x 3 1/2" Bolt
6	6	Joint Plate	32	5	3/8" x 2" Bolt
7	2	Front Upright	33	2	5/16" x 2" Bolt
8	2	Rear Upright	34	3	3/8" x 3" Bolt
9	2	Weight Guide	35	2	3/8" x 2 1/2" Bolt
10	1	Right Frame	36	8	5/16" Washer
11	1	Center Frame	37	12	3/8" Washer
12	1	Left Frame	38	6	3/4" Spacer
13	1	Chin-up Bar	39	1	2" Spacer
14	1	Weight Guide Frame	40	2	15/16" Spacer
15	1	Weight Carriage	41	2	Handgrip
16	2	Carriage Bushing	42	2	2" Round Inner Cap
17	2	Pulley Plate	43	2	Weight Clip
18	2	Weight Bumper	44	1	Strap
19	2	Weight Rest	45	1	Lat Bar
20	2	Weight Spotter	46	1	Cable Clip
21	12	Square Bushing	47	2	Lat Bar Rest Sleeves
22	6	Adjustment Knob	48	2	3/8" Nylon Jamnut
23	2	Cable Trap	49	2	5/16" x 4" Bolt
24	6	3 1/2" Pulley	50	1	4" Pulley
25	2	Cable	#	1	User's Manual
26	4	Weight Clip Sleeve	#	1	Exercise Poster

Note: “#” indicates a non-illustrated part. Specifications are subject to change without notice. See the back cover of the user's manual for information about ordering replacement parts.

Exploded Drawing—Model No. NTBE06900

R1100A

